

GS-1 CR

Gyro Servo
(Continuous Rotation)

Users Manual

www.dunehaven.com

Written by
Scott Armitage

November 2011

Overview

The GS-1 *CR* has the features of a continuous-rotation gear motor combined with gyro stabilization. The gyro senses the speed that the servo is rotating and will attempt to keep it rotating at a fixed speed. This can be very useful for camera mounts to make the camera slowly pan in circles. This can be useful in combination with a camera taking still pictures with an intervalometer or for video. In addition, the gyro will help compensate for movement in the panning direction if the camera mount is not completely stationary.

Normally, when conventional servos are modified for continuous rotation, a pot inside the servo is disconnected to allow the servo to endlessly rotate. The pot gave the servo information about its rotation. Without this pot, the servo is difficult to control and often runs with much less torque unless an external gear reduction is used.

The GS-1 *CR* eliminates these problems by using a gyro to control the motion of the servo. This restores the smooth movement and full torque to the servo. In addition, the gyro helps to stabilize against movement of the rig.

The GS-1 comes in two versions: a standard version and a continuous-rotation version. This manual describes the GS-1 *CR* continuous rotation model. If you need a gyro servo capable of rotating to a known position over a limited rotation angle, you may be interested in the standard GS-1. See dunehaven.com for information on the standard GS-1.

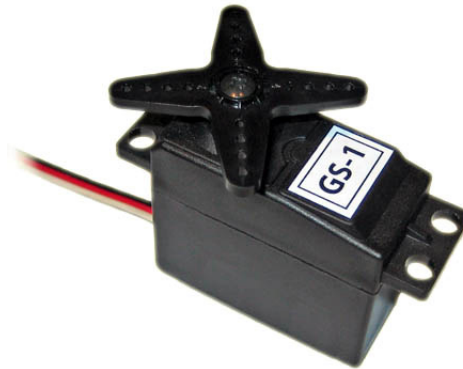

The GS-1 *CR* is the size of a standard-sized R/C servo and it is physically compatible with other popular standard servos.

Dimensions

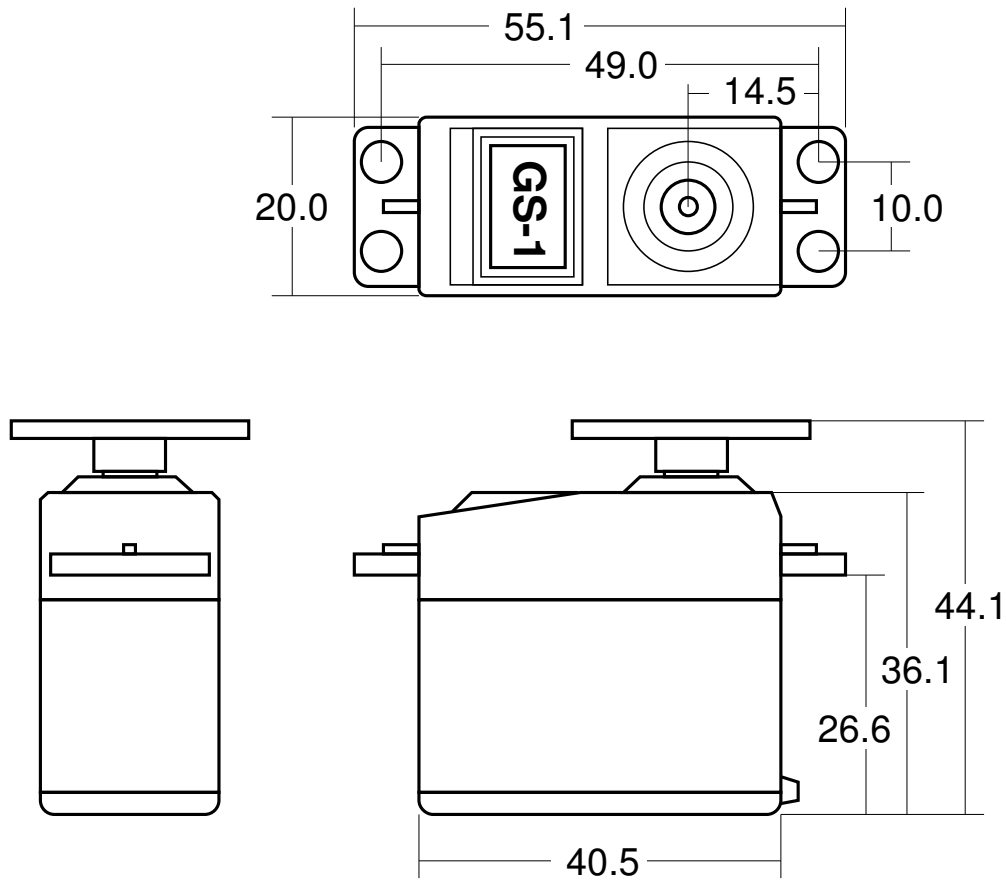

All dimensions in mm

- 360 rotation with no limits on the amount of rotation
- Ball bearing on output shaft
- Nylon gears for smooth operation
- 37 grams (1.3 oz) weight

Installation

Mount the GS-1 *CR* by its mounting flange with the included screws or small bolts. It is recommended that all four mounting holes be used. Do not support any significant amount of weight from the servo shaft if the failure of the servo could result in damage to your equipment or to other objects or people.

Plug the GS-1 *CR* into an R/C receiver like any other servo. The GS-1 *CR* is compatible with receivers operating at 4.0V to 6.0 V.

The GS-1 *CR* can also be connected directly to a battery without an R/C receiver. In this case, plug the GS-1 *CR* into the included 3-pin adapter. Connect the battery to the pins on the other side of the adapter. Make sure the (-) side of the battery (usually a black wire) lines up with the black wire of the GS-1 *CR*.

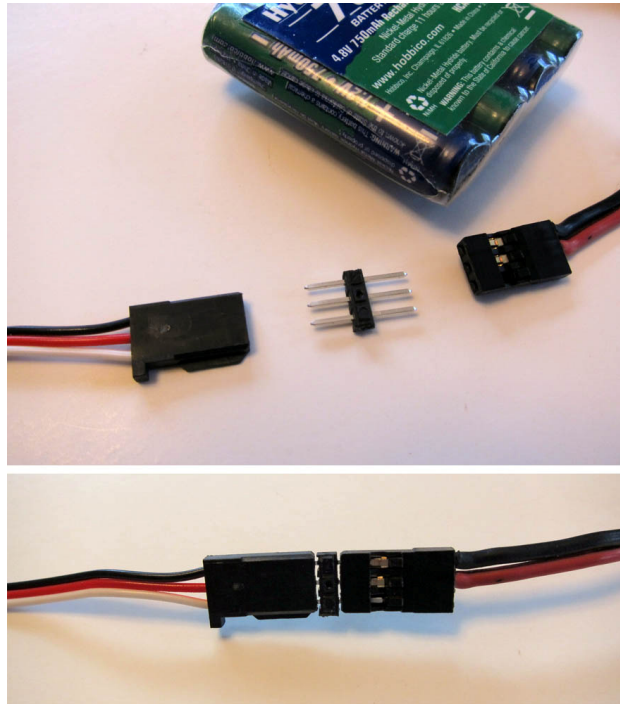

Never connect the GS-1 *CR* to a battery of more than 6.0V.

The GS-1 *CR* can be used with or without a gear reduction. A 3:1 gear reduction works best, but ratios of 1:1 to 5:1 may be used. See the section on “Adjustments” for more information about adapting it for different gearing configurations.

Mounting Orientation

Unlike a standard GS-1, the GS-1 *CR* must be mounted so that the servo senses its own rotation.

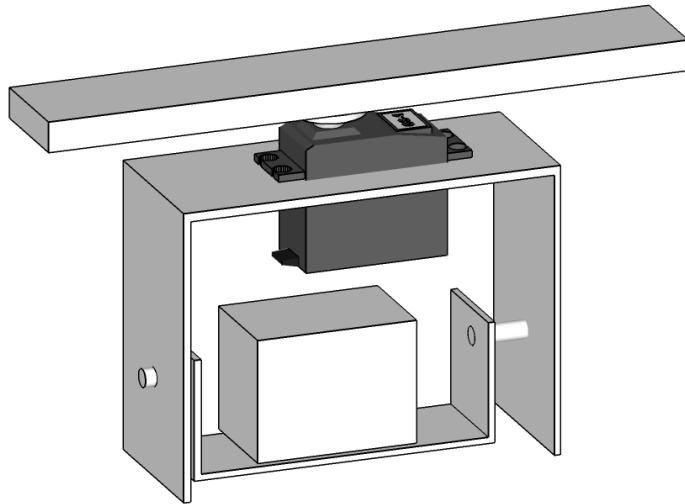

Correct Mounting

Servo turns as
servo output shaft
turns

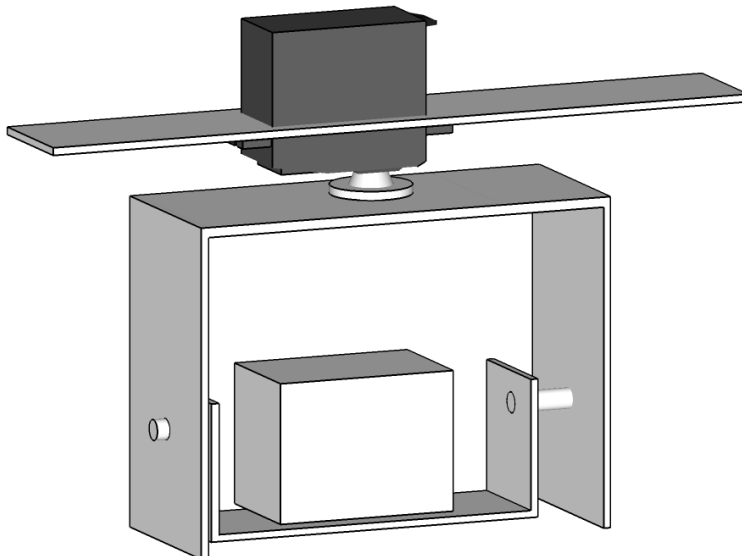

Incorrect Mounting

Servo does not turn
as servo output
shaft turns

Startup

When power is applied to the GS-1 *CR*, there is a two second delay before the GS-1 *CR* starts to function. At the end of this two second period, the GS-1 *CR* calibrates itself. To work properly, the GS-1 *CR* must not be moving at the end of this two second period. The two second duration was chosen to be a convenient amount of time to let you set the equipment on a stable surface during the calibration.

Modes of Operation

The GS-1 *CR* has two modes of operation: Battery Mode and PWM Mode.

Battery Mode

Battery Mode requires only a power source such as a battery and is intended for applications where the equipment needs to slowly and continuously rotate in circles. In Battery Mode, the rotation speed is adjustable with a pot.

PWM Mode

PWM Mode requires connection to an R/C receiver that supplies both power and a servo PWM control signal. In PWM Mode, the signal from a R/C receiver determines the rotation speed. A PWM signal of more than 1550 us will make the GS-1 *CR* turn in one direction. A signal of less than 1450 us will make it turn in the other direction. The more the signal changes in width, the faster the GS-1 *CR* will turn.

The GS-1 *CR* will automatically switch from one mode to the other depending on whether it detects a PWM signal from an R/C receiver.

Usage

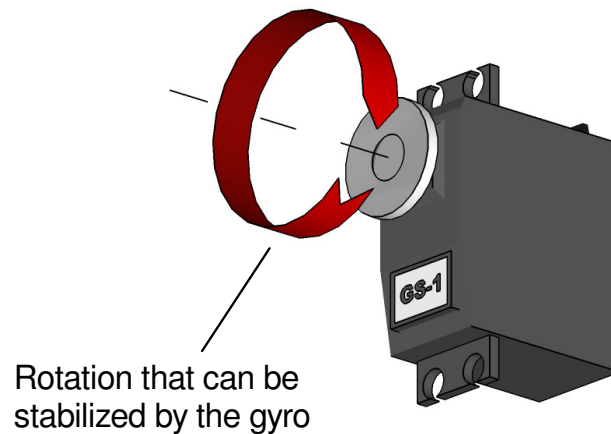

To familiarize yourself with the operation of the GS-1 *CR*, please do the following experiment before installing the GS-1 *CR*.

- Either connect directly to only a battery or connect to a R/C receiver. If using a receiver, move the radio controls to one side to avoid sending a 1500 us pulse signal.
- Power up the GS-1 *CR* while holding the body of the GS-1 *CR*. Avoid moving it during its power-on calibration.
- Rotate the servo body back and forth. You should observe that the GS-1 *CR* spins its output shaft quickly in one direction or the other based on how it is turned in your hand.
- Shift your hands so you are now holding the GS-1 *CR* by the “X” shaped servo horn. The GS-1 *CR* should immediately stop spinning and the body of the GS-1 *CR* will slowly turn. This is how the GS-1 *CR* should be used in your application – Fix the servo shaft to the more stationary object and let the servo turn with the equipment you wish to turn at a constant rate.

In PWM mode, the speed of rotation can be changed via the R/C transmitter.

Adjustments

Two adjustments are provided on the GS-1 CR: Speed and Stability

To adjust the GS-1 CR, locate the two small holes in the bottom of the plastic case. Adjustment pots are located behind these holes. Use a flat bladed screwdriver of 2.0 x 0.5 mm (maximum) to adjust the pots, such as the Wiha 26020.

Note: Be very careful not to turn with too much force or you may break the stop at the end of the pot's rotation. Hold the screwdriver by its shaft rather than by its handle when adjusting the pots.

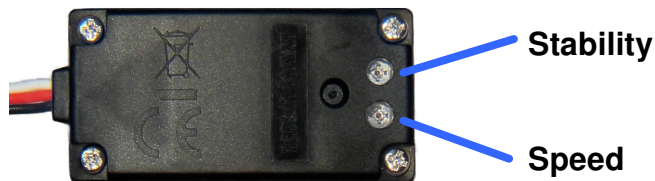

Speed Adjustment

In Battery Mode, a Speed pot affects the rotation speed. In PWM mode, the Speed pot is not used.

To adjust rotation speed in Battery Mode, turn the Speed pot. Changing the pot will change the rotation speed from about one revolution every 30 seconds to one revolution every 5 minutes.

Note that it is not possible to change the direction of motion in Battery Mode – only the speed is adjustable. It is possible to change the direction in PWM Mode.

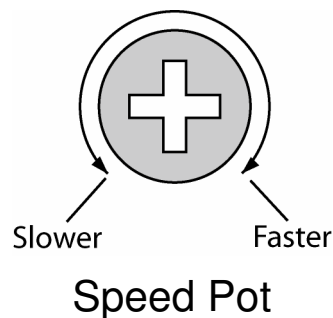

Stability Adjustment

Because the GS-1 *CR* senses its own rotation, the GS-1 *CR* must know how much of this motion to ignore so it can focus only on controlling the slow rotation of the servo. This will be dependant on many factors, such as the weight of the object the GS-1 *CR* is turning, gear reduction (if any) and the “stiffness” of the rig’s support.

Because this can change from one application to another, there is a Stability pot. If the camera rig shakes back and forth in the direction that is controlled by the GS-1 *CR*, turn the pot counter-clockwise. To make the rig respond faster and more smoothly, turn the Stability pot clockwise.

The Stability pot also controls whether the GS-1 *CR* compensates for gears on the GS-1 *CR*. If there is no gearing used, the Stability pot must be set to the half of its rotation that is the most clockwise. When used with gearing, the Stability pot must be in the half of its range that is the most counter-clockwise. The GS-1 *CR* works best with gear reductions of 1:1 to 4:1. Do not use reverse gear ratios where the larger of the two gears is mounted to the servo shaft.

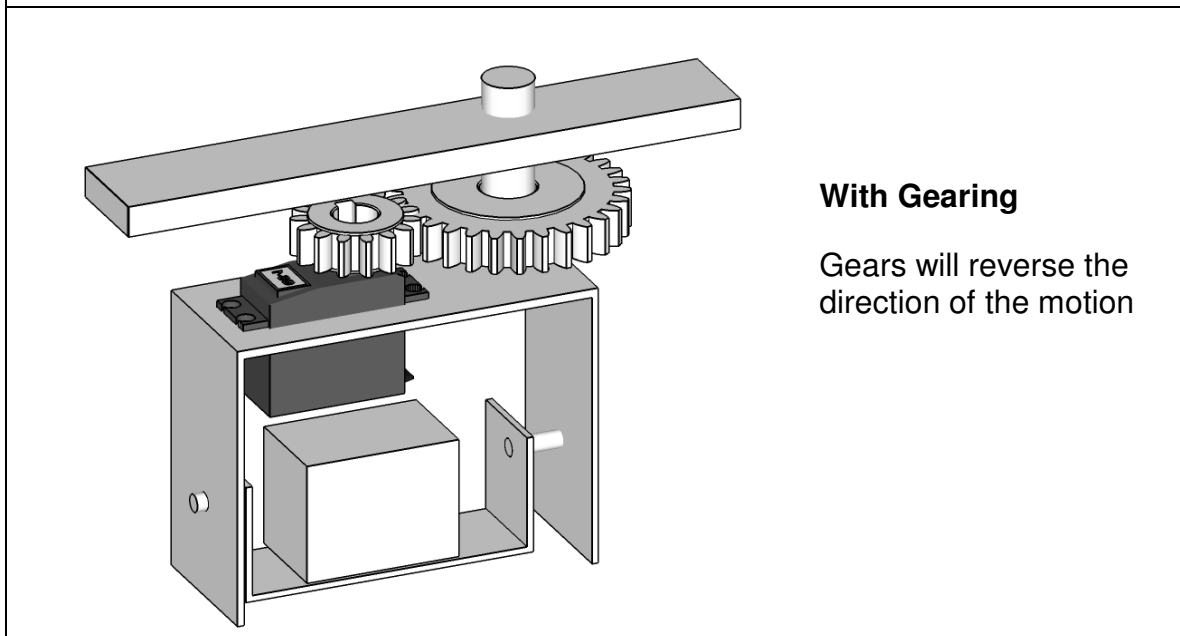
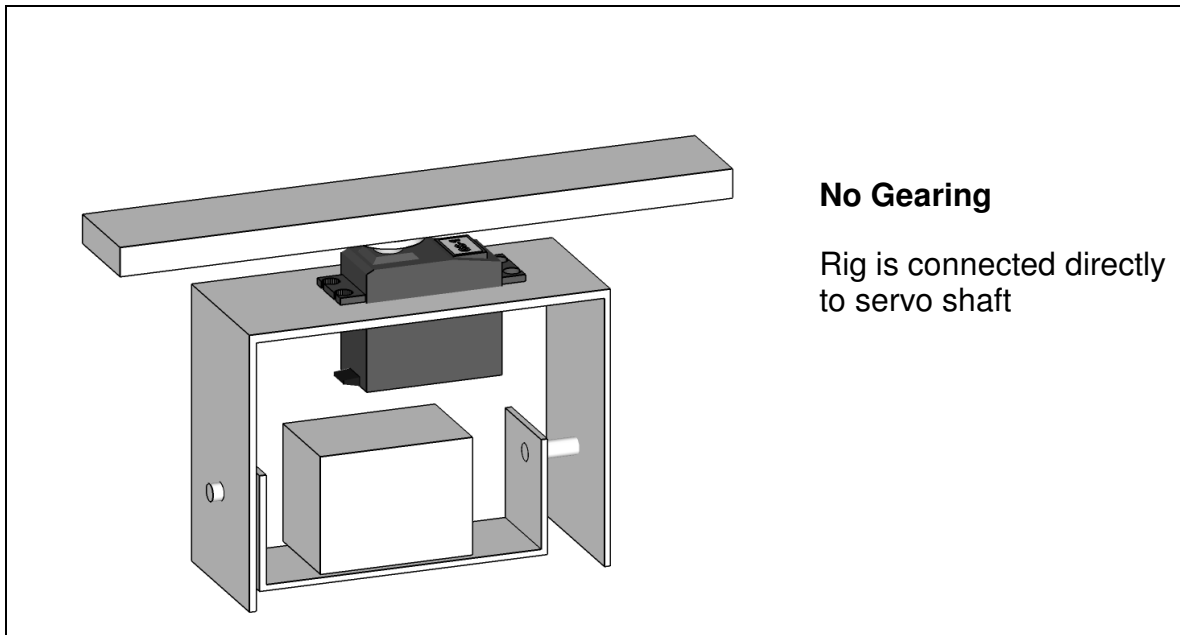

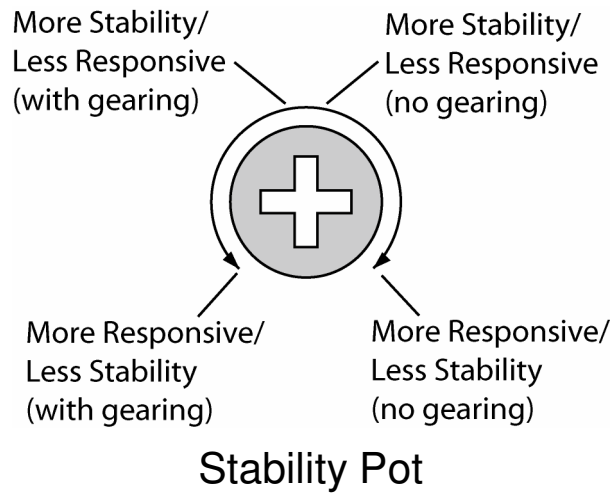

Here are some typical situations and good starting points for adjusting the Stability pot:

Configuration	Stability Pot Setting
No gearing	Slightly CW from center
1:1 gears (no reduction)	Slightly CCW from center
4:1 gear reduction	Full CCW
4:1 gear reduction with heavy load	Half way CCW

CW = Clockwise

CCW = Counter-clockwise / Anti-clockwise

FAQ

Can I use a GS-1 CR for panning a camera and a standard GS-1 for tilt or roll?

Yes.

When I power up the GS-1 CR it just spins rapidly.

When testing the GS-1 CR, you must hold the GS-1-CR by its output shaft, not by the servo body.

Can I use the GS-1 CR where the servo is mounted 90 degrees to the rotation axis of the object being moved (e.g. worm gear or bevel gear drive)?

The GS-1 CR is not compatible with these types of mountings.

Is the GS-1 CR susceptible to gyro drift?

In Battery Mode, the GS-1 CR is always rotating slowly so drift is not an issue. If the servo motion is stopped with a 1500 us pulse input, the GS-1 CR may drift but this drift is usually at a rate of 1 turn every 5 minutes or slower.

What batteries are compatible with the GS-1 CR?

You need a battery of 4.0V to 6.0V or a voltage regulator with a 5.0V output. Do not connect directly to LiPo batteries. A good choice for a GS-1 CR battery is the HydriMax Ultra 750 (Model HCAM6301). It is easiest to use a battery designed for driving an R/C receiver with a 3-pin servo connector.

Support

Questions regarding the GS-1 *CR* can be sent via email. See the Contact link at www.dunehaven.com.

Legal

The design of the GS-1 *CR* system is Copyright © 2009-2011 Scott Armitage. This includes the electrical design, the circuit board layouts and all software designed for the system. You may not reverse engineer, decompile, or disassemble any GS-1 *CR* software nor may you reverse engineer the GS-1 *CR* hardware for any reason.

Limited Warranty

The GS-1 *CR* system is warranted to be free from defects in materials and workmanship for a period of one year from the date of purchase. This limited warranty covers normal use and does not cover abuse or use not in accordance with this manual.

Under no circumstance will the seller be responsible for any incidental or consequential damages, which may occur during the use of the product, or as a result of the product's failure to perform. In all cases, the customer's sole remedy for a product failure is limited to the repair or replacement of the product.